

PHOTOGRAPH THIS SHEET

ADA995043

DTIC ACCESSION NUMBER

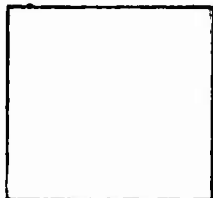

LEVEL

Army Engineer R & D Labs,
Ft. Belvoir, VA.



INVENTORY

"The Effects of Atomic Weapons on Engineer
Heavy Equipment" Rpt. No. 1443

DOCUMENT IDENTIFICATION

Project 8-12-75-001

Date: 25 Apr. '56

DISTRIBUTION STATEMENT A

Approved for public release;
Distribution Unlimited

DISTRIBUTION STATEMENT

ACCESSION FOR	
NTIS	GRA&I <input checked="" type="checkbox"/>
DTIC	TAB <input type="checkbox"/>
UNANNOUNCED	<input type="checkbox"/>
JUSTIFICATION	
(25 April 1956)	
BY	
DISTRIBUTION /	
AVAILABILITY CODES	
DIST	AVAIL AND/OR SPECIAL
A	

Released

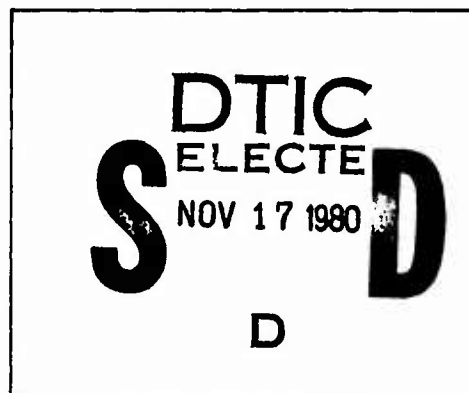

DATE ACCESSIONED

DISTRIBUTION STAMP

UNANNOUNCED

80 11 12 114

DATE RECEIVED IN DTIC

PHOTOGRAPH THIS SHEET AND RETURN TO DTIC-DDA-2

3496

7868

ADA995043

EKB
#61
2/19/61

UNCLASSIFIED



#33

RATN

TEMP O
A9870
C69

DEPARTMENT OF THE ARMY
CORPS OF ENGINEERS



TECHNICAL LIBRARY
of the
ARMED FORCES
SPECIAL WEAPONS PROJECT



TECHNICAL LIBRARY
FEB 14 1957
a/19235
#33
ARMED FORCES
SPECIAL WEAPONS PROJECT

Report 1443

THE EFFECTS OF ATOMIC WEAPONS ON
ENGINEER HEAVY EQUIPMENT (U)

Project 8-12-75-001

25 April 1956

DIA ✓
DOC ✓
SVC ✓
DFOI ✓

~~RESTRICTED DATA~~

~~ATOMIC ENERGY ACT 1954~~

ENGINEER RESEARCH

Classification (Cancelled)
By Authority *75 Review ONH/DOC*
By *EG AND CHILSON* date *04/56*

DEVELOPMENT LABORATORIES

STATEMENT A
REGARDING DATA CANNOT BE DETERMINED
Approved for public release
Distribution unlimited.
EXCLUDED FROM AUTOMATIC DOWNGRADING
DOD DIR 5200.10-2 DOES NOT APPLY

~~RESTRICTED DATA~~
This material contains Restricted
Data as defined in the Atomic Energy
Act of 1954. Its dissemination
or disclosure to unauthorized
person is prohibited.

THE ENGINEER CENTER

FORT BELLEVILLE

80 11 12 114

TBL-46-61
2/19/61
COPY 69 OF 125 COPIES

083-75-21506
(Z77-1384, c.1)

UNCLASSIFIED

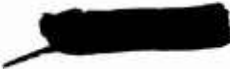

ENGINEER RESEARCH AND DEVELOPMENT LABORATORIES
CORPS OF ENGINEERS
UNITED STATES ARMY

Report 1443

THE EFFECTS OF ATOMIC WEAPONS ON
ENGINEER HEAVY EQUIPMENT (U)

Project 8-12-75-001

25 April 1956

Submitted to
THE CHIEF OF ENGINEERS, U. S. ARMY

by

The Director
Engineer Research and Development Laboratories
Corps of Engineers, United States Army

Prepared by

Robert C. Nelson, Capt., CE
Special Projects Branch
Military Engineering Department
Engineer Research and Development Laboratories
Corps of Engineers, United States Army
Fort Belvoir, Virginia



ATOMIC ENERGY ACT 1954

TABLE OF CONTENTS

<u>Section</u>	<u>Title</u>	<u>Page</u>
	ABSTRACT	v
I	INTRODUCTION	
	1. Subject	1
	2. Background and Previous Investigation	1
	3. Personnel	1
II	INVESTIGATION	
	4. Layout	1
	5. Inspection and Instrumentation	5
	6. Test Results	5
III	DISCUSSION	
	7. Relative Vulnerability	28
	8. Effectiveness of Slots	28
	9. Damage Criteria	31
IV	CONCLUSIONS	
	10. Conclusions	31
	BIBLIOGRAPHY	33

ABSTRACT

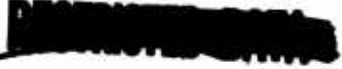
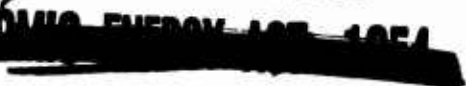
At Exercise DESERT ROCK VI, Operation TEAPOT, items of Engineer heavy equipment were exposed to the effects of atomic weapons. The test objective was to augment the damage criteria data contained in TM 23-200, The Capabilities of Atomic Weapons (SECRET), and to evaluate elementary protective measures.

It is concluded that:

a. The vulnerability of different items is proportional to their complexity and to their design purpose. Heavy duty earth moving equipment is simple and sturdy, and is less vulnerable; truck-mounted equipment is doubly complex, less sturdy, and more vulnerable.

b. Elementary measures, such as bulldozed slots, are effective in protecting Engineer heavy equipment. They permit the protected items to avoid the drag forces, which are the principal cause of severe or moderate damage, even though the peak pressure is approximately doubled by reflection within the slot.

c. The damage criteria contained in TM 23-200 might be considerably improved by inclusion of the data obtained in this test. It could be extended to cover a wider variation in types of equipment. It is also concluded that consideration should be given to scaling ground range for dug-in equipment in the same manner as peak pressure since the evidence obtained in this test indicate peak pressure to be the damaging weapon effect for dug-in items.

* per telecon w/Betty Fox (DIA Tech Libr, Chief), the classified references contained herein may remain.

DeLoach (DDA)
9-5-79

*Verified for Extracted Versions, 9 July '83,
pfcooper, DTIC/DDA-2

THE EFFECTS OF ATOMIC WEAPONS ON
ENGINEER HEAVY EQUIPMENT (U)

I. INTRODUCTION

1. Subject. This report covers an investigation conducted at Exercise DESERT ROCK VI, Operation TEAPOT, where items of Engineer heavy equipment were exposed to the effects of atomic weapons. The objective of this project was to augment the damage criteria data contained in TM 23-200, The Capabilities of Atomic Weapons (SECRET) and to evaluate simple protective emplacements.

2. Background and Previous Investigation. Subsequent to Operation CROSSROADS in 1946, continuous efforts have been made to collect data on the vulnerability of military items to atomic weapons and to establish protective measures. The results form the damage criteria curves of TM 23-200 which are presented for two categories of mobile equipment, namely, military vehicles (generally considered to be truck mounted) and tanks or artillery. All types of military equipment are not represented; however, reasonable estimates of distances to which other equipment may be damaged can be arrived at by associating the item in question with other items of equipment for which damage criteria curves are given. Engineer heavy equipment falls in the "other equipment" category and the most important questions to be resolved concern severe and moderate damage and the effectiveness of elementary protective measures. Authority was obtained for limited participation in Operation TEAPOT at the Nevada test site in 1955, under Project 8-12-75-001, "Tessie Jones".

3. Personnel. The test was conducted as a subproject under the supervision of Mr. Nathaniel J. Davis, Jr., in conjunction with other field work under the direction of Mr. John G. Lewis, both of whom are employed in Special Projects Branch, Engineer Research and Development Laboratories, Fort Belvoir, Virginia. Personnel from The Engineer School comprised of Capts William M. Carey and Charles J. White, Sgts C. L. Thompson, W. R. Hardwick, H. L. Viar, and L. C. McKee served as the members of the evaluation team. Personnel from Camp Desert Rock, and the 95th Engineer Combat Battalion participated in the work. The AFSWP and the Naval Ordnance Laboratories provided essential support. Cpl Marvin Adelberg executed portions of the planning and setup phases. Capt Robert C. Nelson, Special Projects Branch, wrote the report.

II. INVESTIGATION

4. Layout. From TM 23-200, the damage criteria for tanks and trucks as well as Engineer heavy equipment were tabulated, scaled to the shot conditions of the predicted yield (28 ± 3 KT) and height of burst (400 ft). (See Table I.)

[REDACTED]

[REDACTED]

[REDACTED]

Table I. Damage Criteria*

Item	Range (ft)				
	Exposed			Protected	
	Severe	Moderate	Light	Severe	Light
Tanks	1175	1740	4,000	590	1175
Engineer Heavy Equipment	1810	2335	5520	905	1810
Trucks (heavy and light)	2440	2930	7040	1220	2440

* Predictions from Figs. 102 and 103 of TM 23-200 for 28 KT yield.

Table I gives distances at which equipment ranging from trucks to tanks would receive various amounts of damage when subjected in the exposed and protected state. In accordance with TM 23-200 ranges for Engineer heavy equipment are shown at distances midway between those ranges for trucks and tanks, and severe damage to protected or dug in equipment is listed at ranges 50% of those where severe damage would be expected in the exposed situation. The light damage range for protected equipment is that range at which exposed equipment would receive severe damage; or, more simply, digging in reduces the severe damage level by two. Five items of equipment were selected to represent the variety of types and sizes of engineer equipment available. They were, in the expected order of vulnerability: tractors, graders, cranes, air compressors, and motor generator sets. To determine the test layout all aspects of the equipment were considered in conjunction with existing damage criteria presented in Table I. Each item of equipment was evaluated as to vulnerability by considering such characteristics as size, weight, and surface conditions (whether paneled or open) as well as the overall sturdiness or job assignment. Other important considerations were: (1) Much of the equipment was truck mounted and would respond more like trucks than tanks, and (2) the shot conditions were designed to produce a precursor which increases dynamic pressure relative to peak pressure and equipment is more sensitive to dynamic pressure (drag and drag forces). Further, it was deemed advisable to exclude the extremes for light damage as the magnitude of the test would have been greatly increased to cover this category without proportionately affecting the results in the area of interest (severe and moderate damage). In order to form valid conclusions it was desirable to subject duplicate items of equipment, one exposed and one protected, at the same range and at ranges where exposed pieces would undergo severe and moderate damage. Damage above or below this amount would be deleterious as the success of a test of this type depends upon positive comparisons of test items after exposure. Because a high degree of damage was sought, it was felt that unserviceable equipment could be used for the test with large savings in cost and without affecting the validity of the results. The simplest kind of protective measures were likewise desired for cost reasons; only bulldozed slots were specified. The layout, shown in Fig. 1, is summarized in Table II. The duplicate items were ~~shown in Fig. 1, 2, 3, 4, 5, 6, 7, 8, 9, 10, 11, 12, 13, 14, 15, 16, 17, 18, 19, 20, 21, 22, 23, 24, 25, 26, 27, 28, 29, 30, 31, 32, 33, 34, 35, 36, 37, 38, 39, 40, 41, 42, 43, 44, 45, 46, 47, 48, 49, 50, 51, 52, 53, 54, 55, 56, 57, 58, 59, 60, 61, 62, 63, 64, 65, 66, 67, 68, 69, 70, 71, 72, 73, 74, 75, 76, 77, 78, 79, 80, 81, 82, 83, 84, 85, 86, 87, 88, 89, 90, 91, 92, 93, 94, 95, 96, 97, 98, 99, 100~~ slots as shown in Fig. 2.

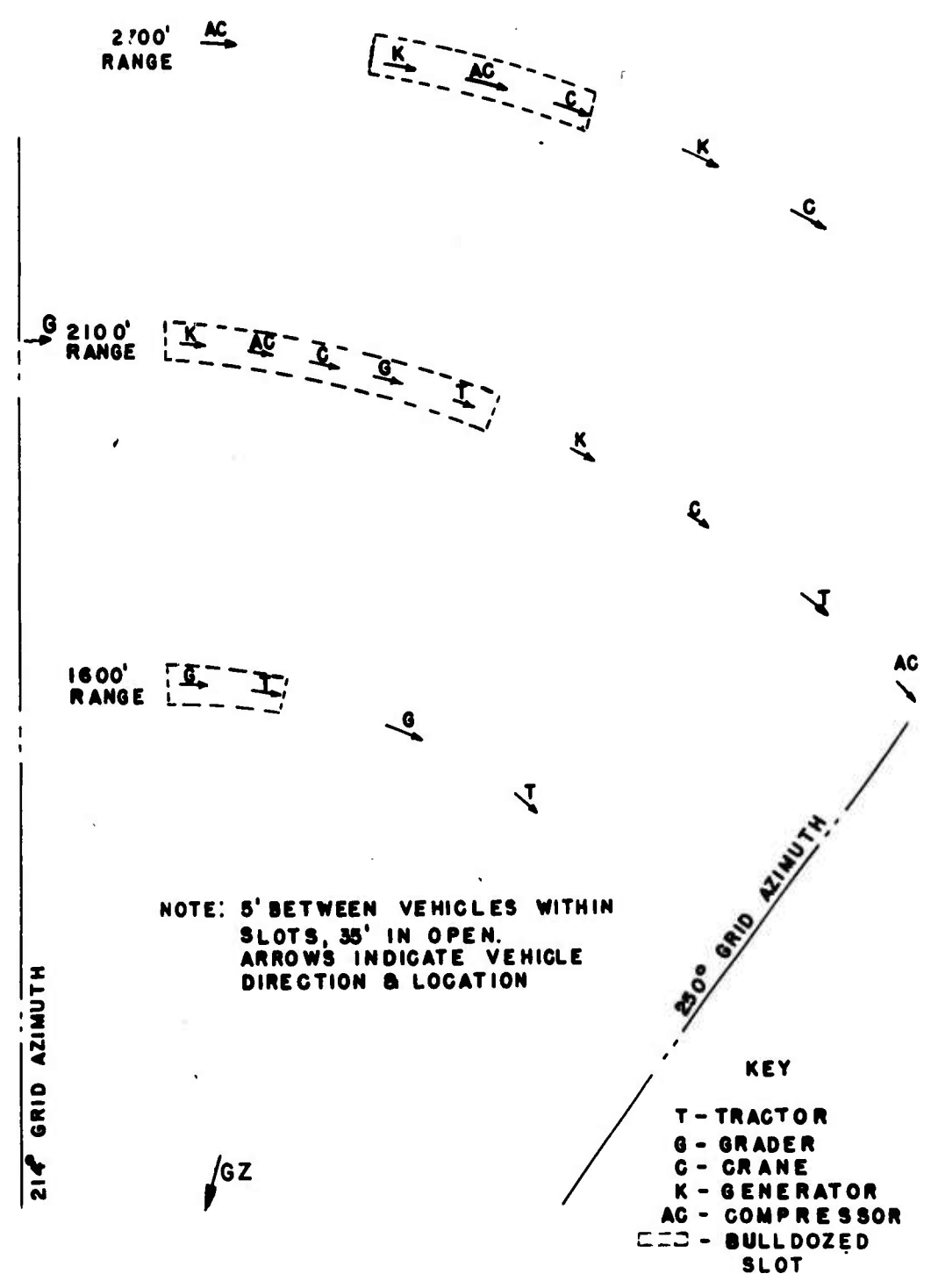

Fig. 1. Layout of equipment relative to ground zero.

Table II. Layout

Item	Range (ft)	
	Severe Damage	Moderate Damage
Tractor	1600	2100
Grader	1600	2100
Crane	2100	2700
Compressor	2100	2700
Generator	2100	2700

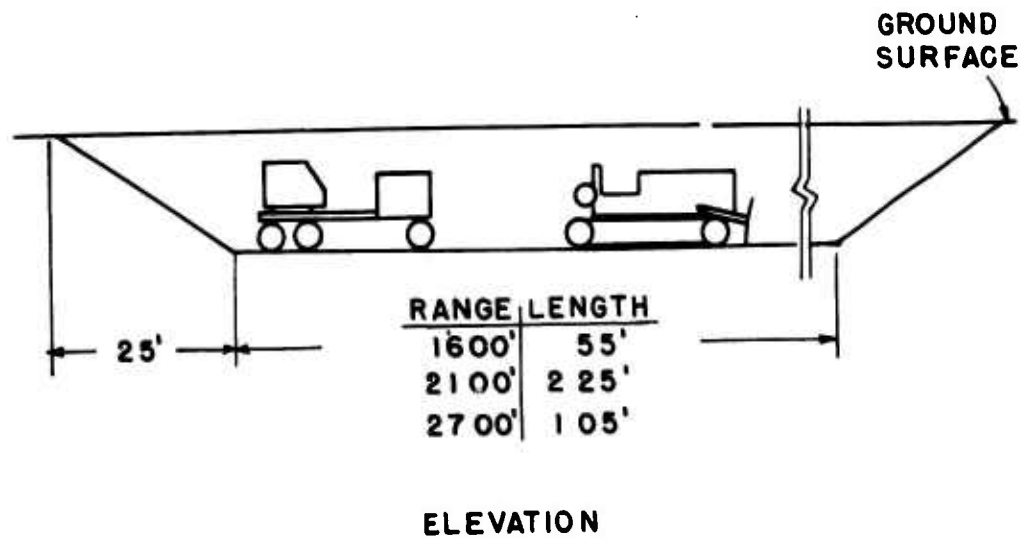
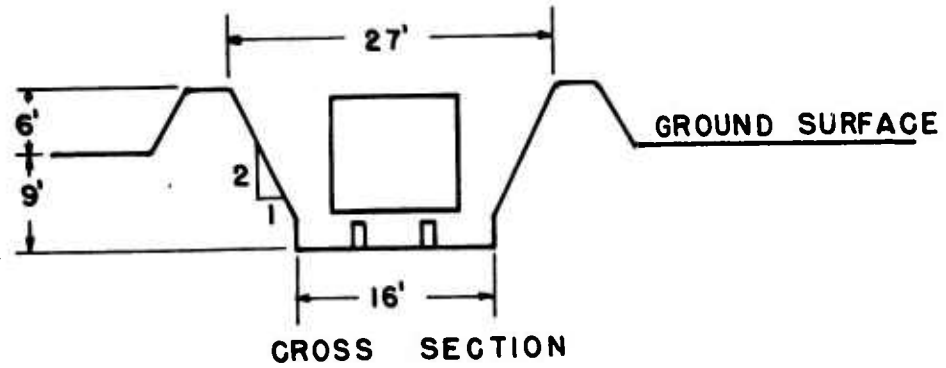

Fig. 2. Slot dimensions.

5. Inspection and Instrumentation. The serviceability of, and required repairs for, the equipment were evaluated by a team from the Mechanical and Technical Equipment Department, The Engineer School. DA Form 464 was completed at the site for each item before and after the shot. Careful attention was given to the definition of damage levels so as to relegate minor observations such as glass breakage, scorched paint, and dented fenders to their proper importance. Black and white still photography was used to supplement the technical inspection as well as to provide a record for report and other purposes. Sufficient indenter gages were available to provide a check of peak pressure within the slots. These were grouped in clusters of three, and five clusters were installed through a cross section of the 1600-ft and 2100-ft slots. The gages were mounted with faces parallel to the soil surface on threaded lag screws in a 6-in. by 6-in. post set firmly in the walls or floor of the slots (Fig. 3).

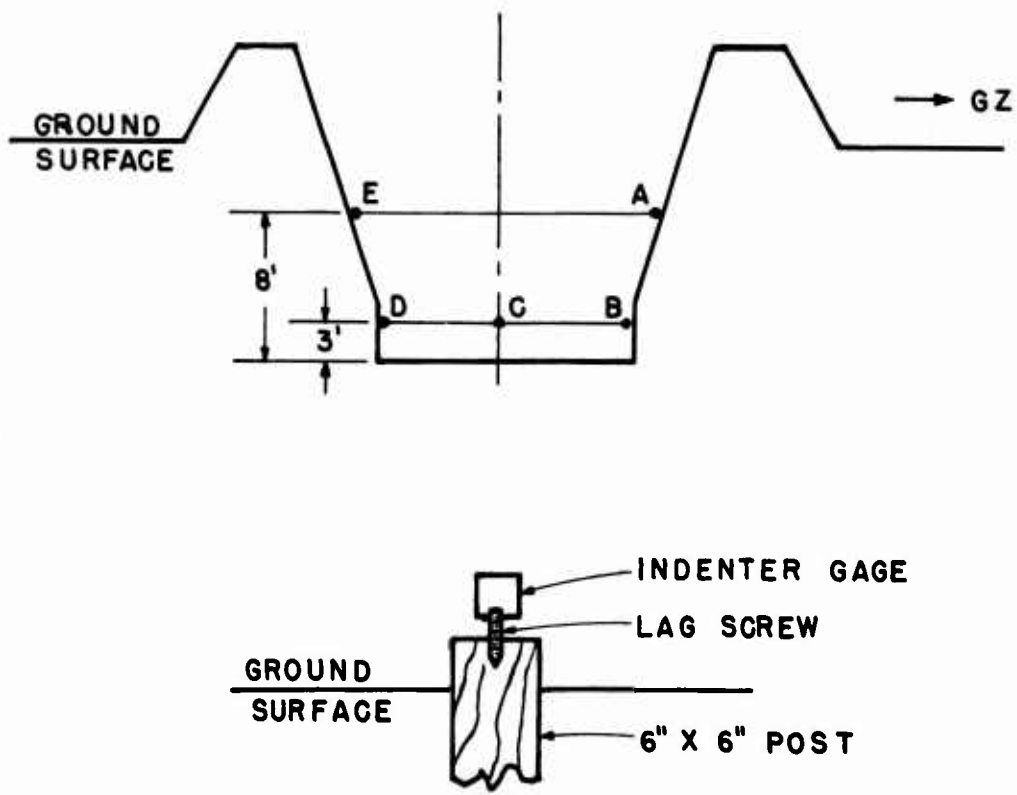

Fig. 3. Instrument location and mounting.

6. Test Results. A high level of damage was obtained. At the respective closer ranges, the exposed items were destroyed, rather than severely damaged as had been predicted. At the

respective greater ranges, the items were moderately damaged as had been predicted. The comparable protected items were damaged to a lesser degree by at least one level on the scale. A summary of damage is presented in Table III; more detailed results are shown in Table IV.

Table III. Summary of Damage

Type	Exposed		
	Damage at 1600 Ft	Damage at 2100 Ft	Damage at 2700 Ft
Tractor	Destroyed	Moderate*	
Grader	Destroyed	Moderate	
Crane		Destroyed	Moderate
Compressor		Destroyed	Moderate
Generator		Destroyed	Moderate
	Protected		
Tractor	Light	Light	
Grader	Light	Light	
Crane		Moderate	Moderate*
Compressor		Light	Light
Generator		Moderate	Light

* Damage was of the moderate category, but was not so extensive as comparable entries in terms of repair effort.

a. Tractors. At the 1600-ft range, the exposed D-6 tractor was completely destroyed. Dismemberment extended to primary assemblies and no component went unscathed. The D-8 tractor in the slot received only superficial damage; it could have been repaired by the operator. The sand blown into the slot was drawbar deep, but could not have prevented movement of the tractor. At the 2100-ft range, the exposed D-7 tractor received much less damage, although damage still exceeded organizational capabilities for repair. The protected D-7 tractor received damage essentially identical to the D-8 at 1600 ft. The use of unserviceable equipment for test purposes prevented an on-the-spot test of the observed condition of

CONFIDENTIAL

Table IV. Summary of Results

Item	Site (ft)	Degree of Destruction	Damage Incurred	Remarks
Tractor Crawler Mounted, DED Caterpillar D-6	1600 Exposed	DESTROYED	Displaced 175 ft and rolled four times. Transmission housing and engine casting at rear of block broken; left track frame assembly, PCU, and blade torn off; equalizer spring approximately 50 ft away from tractor; right track frame assembly torn loose; radiator destroyed; and main frame warped and distorted.	Emplacement provided excellent protection.
Tractor Crawler Mounted, DED Caterpillar D-8	1600 Protected	LIGHT	Hood and exhaust stack torn off. Four hours required for repair.	
Tractor Crawler Mounted, DED Caterpillar D-7	2100 Exposed	MODERATE	Displaced 5 ft and turned up on left side. Instrument panel, fuel tank, and valve covers caved in; hood, air cleaners, and manifold blown off; paint sandblasted on right side; and fan shroud bent against fan. Sixteen hours required to restore to operating condition.	

[REDACTED]

[REDACTED]

RESTRICTED DATA

ATOMIC ENERGY ACT 1954

Table IV (cont'd)

Item	Site (ft)	Degree of Destruction	Damage Incurred	Remarks
Tractor Mounted, DEE Caterpillar D-7	2100 Protected	LIGHT	Hood and throttle controls bent; air cleaner neck on manifold cracked off; and paint and cushions scorched. One hour required to prepare tractor to operate; 2 hours necessary to restore tractor completely.	Emplacement provided excellent protection.
Grader Motorized Caterpillar D-12	1600 Exposed	DESTROYED	Displaced 150 ft and rolled four times. Engine torn completely away from grader; starting engine broken off of diesel engine; left rear, rear wheel broken; front axle broken in two places; forward main frame assembly warped; control housing broken; and radiator assembly destroyed.	
Grader Motorized Caterpillar D-12	1600 Protected	LIGHT	Displaced 2 ft toward GZ and 5 ft forward. Seat, hood, exhaust stack, and air cleaners missing; left rear tire blown out; tie rod bent; and paint sand-blasted on left side. One hour required to prepare grader to operate for limited time; 4 hours necessary to restore grader completely.	Emplacement provided excellent protection.

RESTRICTED DATA

13 AUG 1954

Table IV (cont'd)

Item	Site (ft)	Degree of Destruction	Damage Incurred	Remarks
Grader Motorized Caterpillar D-12	2100 Exposed	MODERATE	Displaced 50 ft and rolled once, stopping upside down. Paint burned on right side; breathers, air cleaners, hood, and seat missing; manifold, radiator, carburetor, fuel gauge, PCU housing, fuel tank, and brake lines broken; controls bent; and two rear tires blown out. One hundred twenty hours required to restore grader completely.	
Grader Motorized Allis-Chalmers	2100 Protected	LIGHT	Cab wrecked and hood bent. One quarter hour required to service grader for limited operation. Sixteen hours necessary to restore it completely.	Emplacement provided excellent protection.
Crane Truck Mounted P&H 255	2100 Exposed	DESTROYED	Displaced 15 ft and rolled once, stopping upside down. All superstructure, housings, and assemblies damaged; and truck cab flattened.	

RESTRICTED DATA

ATOMIC ENERGY ACT, 1954

Table IV (cont'd)

Item	Site (ft)	Degree of Destruction	Damage Incurred	Remarks
Crane Truck Mounted, $\frac{3}{4}$ Yd P&H 255	2100 Protected	MODERATE	Cabs caved in; crane radiator pushed into fan; and other crane machinery blocked and obstructed. Five manhours required to dig out and start prime-mover; 135 hours necessary to restore completely.	Emplacement provided fair protection.
Crane Truck Mounted, $\frac{3}{4}$ Yd, Lorain MC-3	2700 Exposed	MODERATE	Front of truck moved to 45° aways from GZ. Truck hood, radiator, carburetor, right fender, and part of cab blown off; and all other sheet metal caved in, blocking and obstructing crane machinery. One hundred twenty hours required for repair.	
Crane Truck Mounted TIFD-20	2700 Protected	MODERATE	Fuel tanks caved in and sheet metal caved in or blown off. Crane control levers bent and crane moved slightly to right on roller paths. Five hours required to dig out and start prime mover; 38 hours necessary for complete repair.	Emplacement provided good protection.
Compressor, Air Truck Mounted GMC-LeRoI	2100 Exposed	DESTROYED	Displaced 255 ft and rolled many times. Completely dismembered.	

Table IV (cont'd)

Item	Site (ft)	Degree of Destruction	Damage Incurred	Remarks
Compressor, Air Truck Mounted GMC-LeRoI	2100 Protected	LIGHT	Displaced 2 ft toward GZ. Hood missing and windows broken; tool box, hose drum, and compressor hood bent; and fuel tank caved in. Five hours required to put into operation; 9 hours necessary for complete repairs.	Emplacement provided good protection.
Compressor, Air Truck Mounted GMC-LeRoI	2700 Exposed	MODERATE	Displaced 25 ft and rolled over once, stopping on right side. Rear suspension and brake lines broken; hoods, windshield, and right fender missing; and tool box and hose drums bent. Limited operation possible in one hour; 38 hours required for complete repair.	
Compressor, Air Truck Mounted GMC-LeRoI	2700 Protected	LIGHT	Sheet metal bent and glass broken. One man-hour required to service and dig out; 40 hours necessary to restore compressor completely.	Emplacement provided good protection.
Generating Unit Hobart 17G2015	2100 Exposed	DESTROYED	Displaced 100 ft; came to rest on left side. Hood, radiator, distributor, and control panel torn off; and main frame bent. One hundred twelve hours required to completely rebuild the unit.	

RESTRICTED DATA

ATOMIC ENERGY ACT 1954

Table IV (cont'd)

Item	Site (ft)	Degree of Destruction	Damage Incurred	Remarks
Generating Unit Hobart 17G2015 25 KVA	2100 Protected	MODERATE	Displaced 3 ft toward GZ and turned over on right side. Radiator destroyed, fan and fan shroud bent; fuel tank collapsed; and control panel wrecked. Fifty-six hours required to restore generator.	
Generating Unit Hobart 17G2015	2700 Exposed	MODERATE	Displaced 15 ft but did not roll. Valve cover, fuel tank filler pipe, and air cleaner blown off; radiator hose broken; fan shroud bent; control panel caved in; and armature cover bent by flying rock. Twelve hours required to restore unit completely.	
Generating Unit Hobart 17G2015 25 KVA	2700 Protected	LIGHT	Fuel tank punctured and bent; and side panels damaged. Four hours required to restore unit completely.	Emplacement provided fair protection.

~~UNCLASSIFIED~~

~~UNCLASSIFIED~~

light damage to the protected tractors. Figs. 4 and 5 show a typical setup and illustrate the condition of the equipment used.



Fig. 4. Caterpillar D-6 bulldozer, 1600 ft; before test. A13096



Fig. 5. Caterpillar D-8 angled dozer, 1600 ft; before test. A13127

RESTRICTED DATA

ARMED SERVICES ACT 1054



AL3309

Fig. 6. Caterpillar D-6 bulldozer, 1600 ft; after test.

~~RESTRICTED DATA~~

~~RESTRICTED DATA~~

Fig. 6 is typical of the complete destruction possible. Originally, the tractor faced away from the camera with GZ to the right. The drag forces caused the tractor to move rapidly; one of the impacts with the ground evidently broke loose the left track; and the last impact evidently was on the left rear so that the tractor went end over end slamming the front into the ground to bend the frame. The blade had been detached earlier. Fig. 7 is typical of moderate damage, characterized by the overturning of the Caterpillar D-7. (Note the dished-in tool compartments on the right side which faced GZ.) The spilled fuel did not burn; the thermal phase had been essentially completed before the shock wave struck; and the negative phase blew the spillage toward GZ. A blade, if present, probably would not have been damaged extensively. Fig. 8 shows the protected Caterpillar D-8 after the test had been conducted at 1600-ft range, and Fig. 9 shows the protected Caterpillar D-7 (without attachments) after the test had been conducted at 2100-ft range.



A13322

Fig. 7. Caterpillar D-7 (without attachments), 2100 ft; after test.

b. Graders. Damage to the graders paralleled that observed for the tractors. At the 1600-ft range, the exposed D-12 grader was completely destroyed although it was displaced and rolled a somewhat shorter distance (150 ft vs. 175 ft) than the comparable tractor. The protected grader showed clearly the impact of the shock wave reflected from the face of the slot; the grader was moved 2 ft toward GZ and laterally 5 ft (it rolled forward away from the ramp leading into the slot). At the 2100-ft range, the exposed

~~RESTRICTED DATA~~

~~ATOMIC ENERGY ACT 1054~~



Fig. 8. Caterpillar D-8 angledozer, 1600 ft; after test. A13314

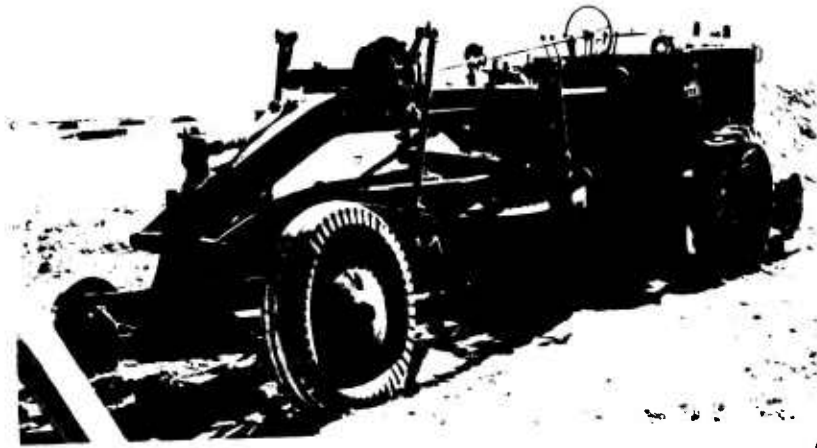

Fig. 9. Caterpillar D-7 (without attachments), 2100 ft; after test. A13327

~~RESTRICTED DATA~~

~~RESTRICTED DATA~~

RESTRICTED DATA
ATOMIC ENERGY ACT - 1954



A13093

Fig. 10. Grader, 1600 ft; before test.

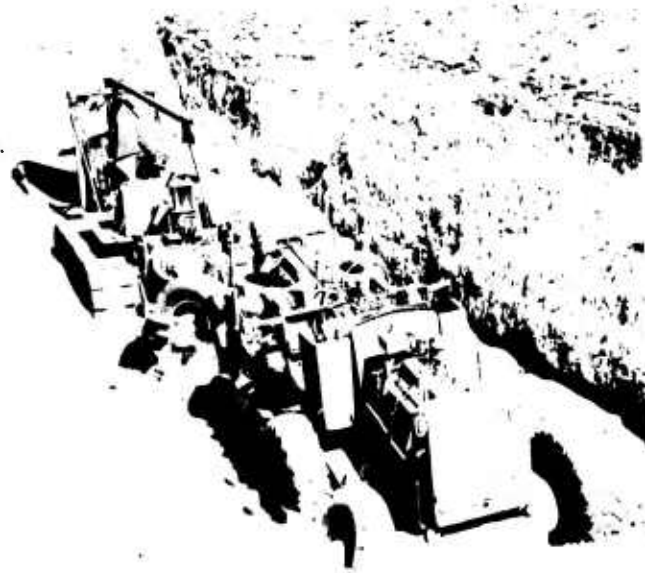

A13317

Fig. 11. Grader, 1600 ft; after test.

grader received moderate damage; the repair effort (120 hr) required was much greater than that for the comparable tractor (16 hr). The protected grader received essentially superficial damage; the wrecked cab would not have prevented the operation of the grader. Figs. 10 and 11 indicate the layout for the graders and the condition of the test items used. In Fig. 11, the wheels show how the reflected shock wave moved the grader toward GZ and forward

RESTRICTED DATA

ATOMIC ENERGY



A13312

Fig. 12. Grader, 1600 ft; after test.

RESTRICTED DATA

ATOMIC ENERGY ACT - 1954

(see also Fig. 8). In Fig. 12, GZ is to the left front; and in Fig. 13, GZ is behind the camera. Fig. 13 shows the condition of the grader after the test was conducted at 2100-ft range. When this figure is compared with Fig. 7, it can be seen that the sturdier, more compact tractor suffered less damage than the grader did under the same conditions.



Fig. 13. Grader, 2100 ft; after test.

A13307

c. Cranes. At the 2100-ft range, the exposed crane was destroyed, and the protected crane received a surprisingly high degree of damage. At the 2700-ft range, the exposed crane still received extensive but moderate damage, while the protected crane was moderately damaged but to a lesser extent because of the shielding effect of the slot. (See Figs. 14 through 19 and note the sheet metal panels of the crane housing and cabs, particularly inside the slots.) Booms and other attachments would have been damaged in about the same degree as the cranes themselves.

RESTRICTED DATA

ATOMIC ENERGY ACT, 1954

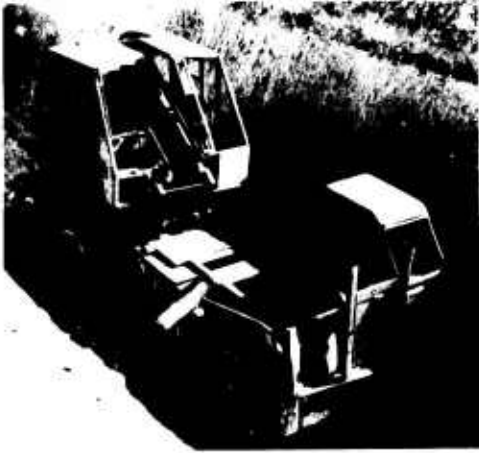

A13204
Fig. 14. Crane, 2100 ft; before test.



A13255
Fig. 15. Crane, 2100 ft; after test.



A13324
Fig. 16. Crane, 2100 ft; after test.



A13306
Fig. 17. Crane, 2100 ft; after test.



A13306
Fig. 18. Crane, 2100-ft; after test. (inset from Fig. 17)



AL3252

Fig. 19. Crane, 2700 ft; after test.

d. Compressors. At the 2100-ft range, the exposed air compressor was destroyed; and at the 2700-ft range, damage was moderate. The slots provided good protection at both ranges; the damage was reduced to the light category and to such a degree that limited operation of the exposed compressor could have been undertaken quickly. The use of unserviceable items prevented an on-the-spot test of the observed light damage. Fig. 20 shows the effect of the reflected shock wave. (Note that the generator is separated from its pallet, and the warped crane and grader cabs as well as the bent cable reel and hoods of the compressor are all slanting toward GZ; a similar but not so intense an effect is indicated in Fig. 21.) Fig. 22 illustrates the complete disintegration in the trail of chassis, engine, compressor, and bed leading back toward GZ. (In Fig. 23, note that the rear suspension was broken when the item rolled over.)

e. Generators. At the 2100-ft range, the exposed generator was destroyed; and at the 2700-ft range, damage was moderate. The slots provided fair protection; at the 2100-ft range, damage was reduced to the moderate category; and at the 2700-ft range, to the light category. Figs. 20, 24, and 25 show the generator separated from its skid or pallet mounting after test (also see Fig. 26). A smaller slot would have limited the reflected shock wave and displacement, and would have decreased the resulting damage.

RESTRICTED DATA

ATOMIC ENERGY ACT 1954



A13329

Fig. 20. Compressor, 2100 ft; after test.



Fig. 21. Compressor, 2700 ft; after test.

A13256

CONFIDENTIAL

RESTRICTED DATA
ATOMIC ENERGY ACT 1954



A13320

Fig. 22. Compressor, 2100 ft; after test.

~~RESTRICTED DATA~~



Fig. 23. Compressor, 2700 ft; after test.

A13318



Fig. 24. Generator, 2100 ft; after test.

A13328

~~RESTRICTED DATA~~

~~RESTRICTED DATA~~

~~RESTRICTED DATA~~
~~ATOMIC ENERGY ACT 105A~~

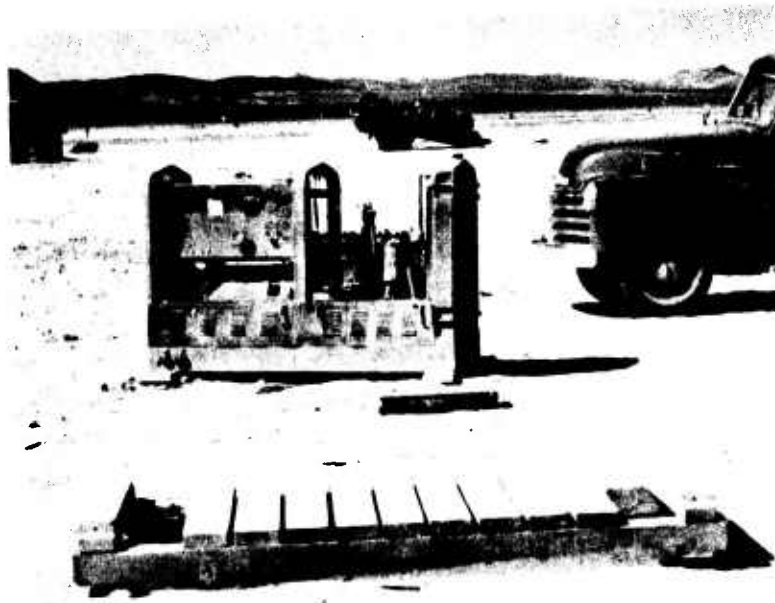

Fig. 25. Generator, 2700 ft; after test.

A13254

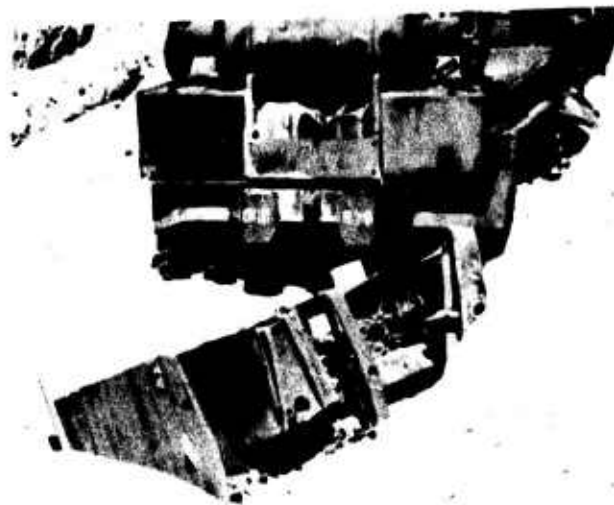

Fig. 26. Generator, 2100 ft; after test.
(inset from Fig. 17)

A13306

UNCLASSIFIED

RESTRICTED DATA
ATOMIC ENERGY ACT - 1954

f. Pressure Measurement. The recorded peak pressures in the slots are shown in Table V. Each in-the-slot measurement exceeded the peak pressure recorded over the surface (approximately 30 and 10 psi for the 1600-ft and 2100-ft ranges, respectively). The variation with location in the slot follows the expected reflection pattern; it is highest at the bottom rear corner facing the blast, and is lowest in the lee of the berm at the top front. The fact that the 1600-ft readings do not proportionately exceed those at 2100 ft may be attributed to the precursor which distorts the blast wave. The pressures over the unobstructed desert floor are shown in Table VI; the more rapid degradation of dynamic than peak pressure is evident.

Table V. Peak Pressures Recorded in Slots

Location	Elevation (ft)	1600-Ft Range		2100-Ft Range	
		Pressure (psi)	Average (psi)	Pressure (psi)	Average (psi)
Front	8	13.5		11.5	
"	8	14.1	14.6	10.5	11.3
"	8	16.3		11.9	
"	3	21.9		17.9	
"	3	*	18.6	16.4	17.4
"	3	15.2		18.0	
Center		26.2		38.3	
"		43.2	31.1	26.6	32.8
"		26.9		33.4	
Rear	3	30.7		25.4	
"	3	36.9	28.1	26.2	25.9
"	3	16.7		26.1	
"	8	21.5		28.2	
"	8	21.2	19.6	30.5	27.6
"	8	16.1		24.2	

* Gage not recovered.

Table VI. Surface Pressures

Range (ft)	Peak Pressure, P_0 (psi)	Dynamic Pressure, q_0 (psi)
1600	30	> 75
2100	10	30
2700	7	5

RESTRICTED DATA

ATOMIC ENERGY ACT 1954

III. DISCUSSION

7. Relative Vulnerability. The vulnerability of equipment is directly proportional to its complexity and inversely proportional to its design purpose. Truck-mounted equipment is doubly vulnerable; damage to either the prime mover or the machinery limits the effectiveness of the whole. Earth moving equipment, which is both single purpose and quite sturdy for its heavy work, is much less vulnerable. Items furnished with cabs and housings, which protect the operators and the machinery from ordinary hazards, are under a further handicap. The broad, smooth panel surfaces reflect the shock wave, and in so doing receive an approximately doubled impact. If the panels collapse or tear off, they become missiles to hammer and wedge shafts, pulleys, and power plants. In addition to the handicap just mentioned, cranes are encumbered by attachments which add to the area exposed to the high winds and drag forces of the blast wave without increasing the strength or stability of the equipment. Of the items tested, the order of vulnerability is:

- a. Cranes
- b. (1) Air compressors
(2) Generators
- c. (1) Graders
(2) Tractors

8. Effectiveness of Slots. Smaller slots would have provided much better protection for the generator. Slots no larger than necessary to contain the generator and to permit its operation would have been preferable. This holds true for all test items; no benefit was derived from the oversized slot for the tractor or grader; and, in some respects, even the crane suffered damage as was witnessed by the severely caved in sheet metal panels on the side away from GZ. Furthermore, for such durable equipment as tractors and graders, a shallower slot, or any measures to prevent overturning, would have been significantly useful in reducing damage in this test. It must be remembered, however, that little possibility of missile hazard existed under the test conditions; deep slots should effectively avoid damage from missiles under other conditions. The contrast in the results between the exposed and protected items illustrates the two different forces associated with a blast wave. Light sheet metal panels, hoods, and fenders were affected both within and outside the slots showing that a strong shock wave struck the items. The big reduction in damage can be attributed to placing the items below the drag forces caused by the high winds associated with the blast wave. These forces, even though of short duration, dragged

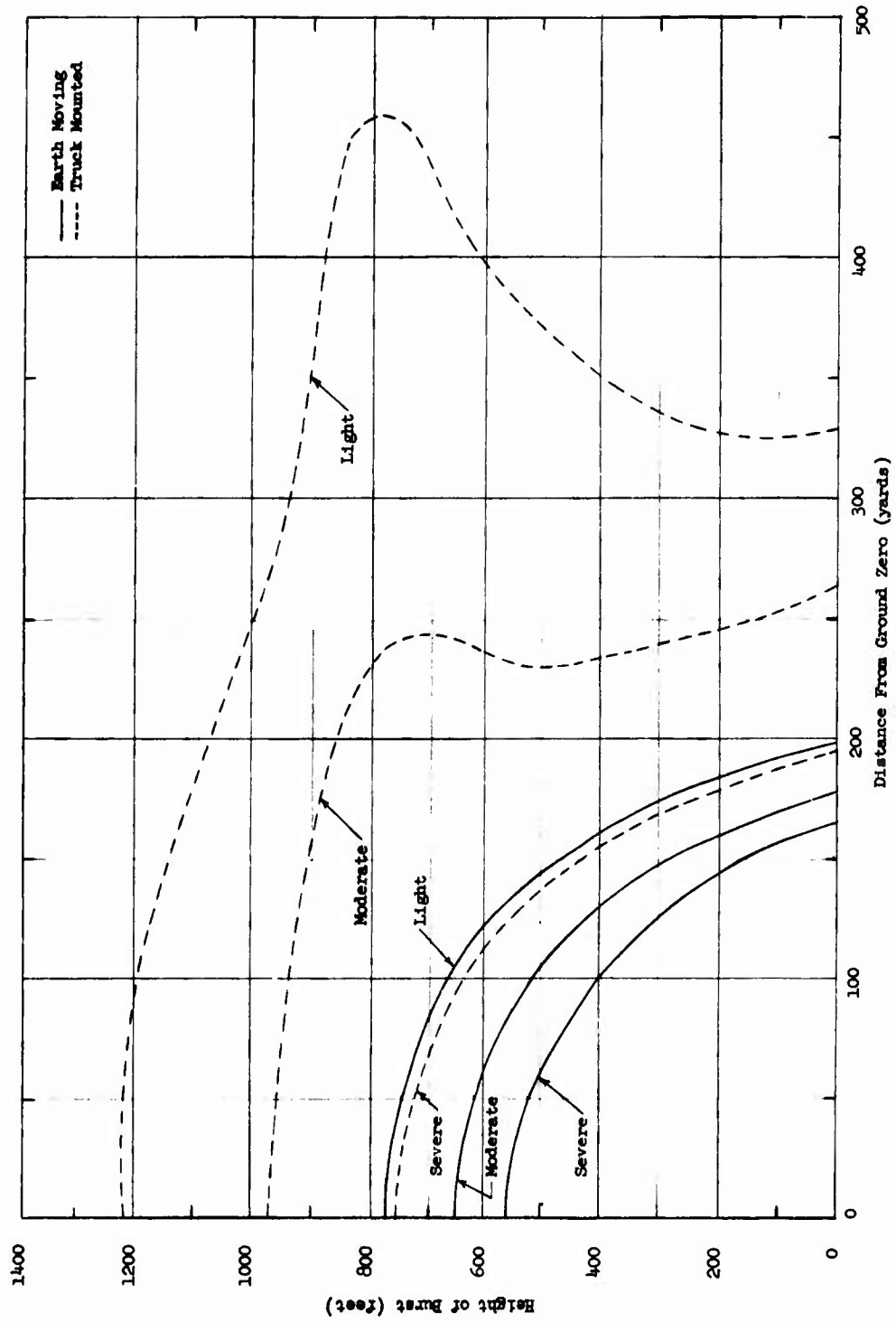

Fig. 27. Height of burst versus ground range damage to protected Engineer equipment scaled to 1 KT.

RESTRICTED DATA
 NATIONAL ACADEMY OF SCIENCES
 BOARD ON ARMS AND AMMUNITION
 REPORT NO. 1054

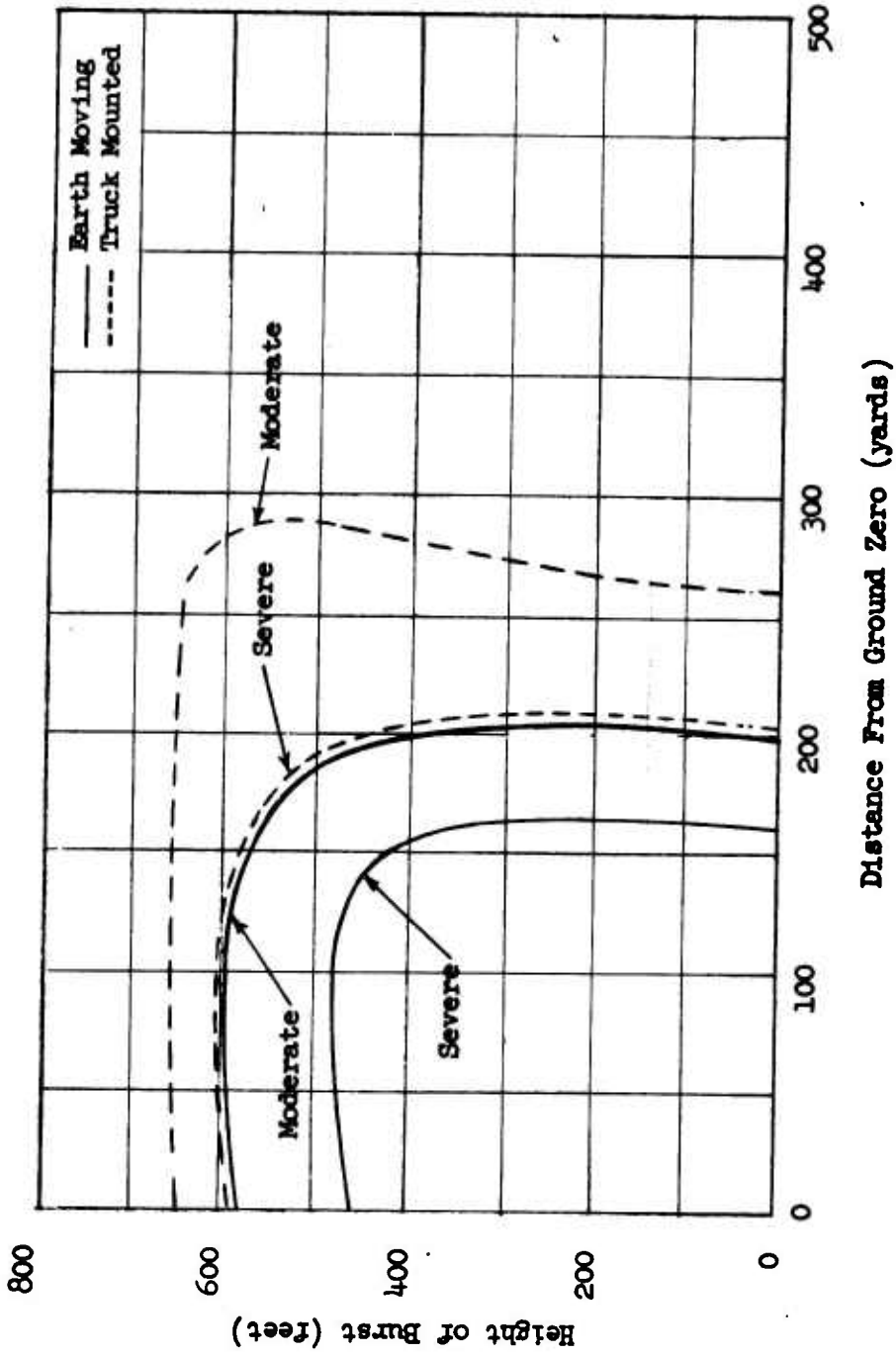

Fig. 28. Height of burst versus ground range damage to exposed Engineer equipment scaled to 1 KT.

UNCLASSIFIED

REDACTED

the items along the ground, overturned them, and rolled them. The accelerating drag forces were not directly responsible for the resulting damage; the decelerating impacts with the ground caused the breakup and destruction. The slots proved effective in reducing damage, so similar measures should provide comparable protection.

9. Damage Criteria. The selected ranges provided an adequately narrow bracket of the range of severe damage. The relatively intense blast effects degrade rapidly because the energy of the blast wave is being attenuated on a volume basis and decreases as the cube root of the range. The 500- and 600-ft range differentials were more than enough to record the change in damage levels. The test showed clearly that all of the exposed items are drag-type targets; they are less responsive to the shock wave itself than to the high winds following the shock. However, it was also clearly evident that the dug-in items were damaged by peak pressure only. Since exposed and dug-in items are damaged by different phenomena associated with the blast wave, it seems profitable to indicate damage criteria in terms of these separate phenomena. Damage criteria in TM-23-200 indicates that damage to drag-type equipment scales as $W^{0.4}$, and peak pressure scales as $W^{1/3}$. Using these scaling methods curves are presented in Figs. 27 and 28 for height of burst versus ground range damage to engineer heavy equipment scaled to 1 KT. In Fig. 27 for dug-in equipment, ground range has been scaled as $W^{1/3}$; and in Fig. 28 for exposed equipment, ground range has been scaled as $W^{0.4}$. Height of burst scales as $W^{1/3}$ in either case. The damage criteria in Figs. 27 and 28 have not been presented in terms of percent probability of damage. However, if it is desired to compare the curves with those given in TM 23-200, it is felt that they should be comparable to the 50 percent probability curves.

IV. CONCLUSIONS

10. Conclusions. It is concluded that:

a. The vulnerability of different items is proportional to their complexity and to their design purpose. Heavy duty earth moving equipment is simple and sturdy, and is less vulnerable; truck-mounted equipment is doubly complex and less sturdy, and is more vulnerable.

b. Elementary measures, such as bulldozed slots, are effective in protecting Engineer heavy equipment. They permit the protected items to avoid the drag forces, which are the principal cause of severe or moderate damage, even though the peak pressure is approximately doubled by reflection within the slot.

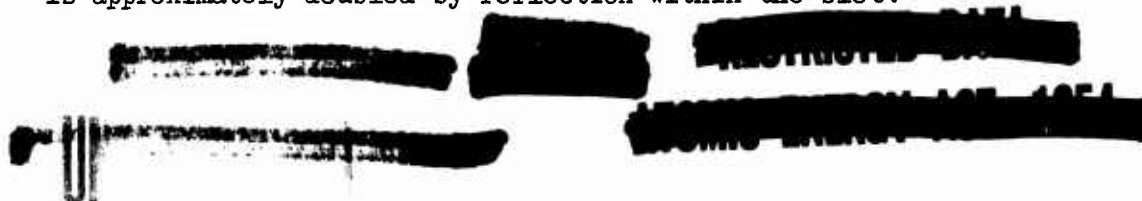

c. The damage criteria contained in TM 23-200 might be considerably improved by inclusion of the data obtained in this test. It could be extended to cover a wider variation in types of equipment. It is also concluded that consideration should be given to scaling ground range for dug-in equipment in the same manner as peak pressure since the evidence obtained in this test indicate peak pressure to be the damaging weapon effect for dug-in items.

RESTRICTED

[REDACTED] [REDACTED] RESTRICTED DATA
[REDACTED] [REDACTED] ATOMIC ENERGY ACT - 1954

BIBLIOGRAPHY

Bryant, E. J., Ethridge, N. H., and Keefer, J. H., "Basic Blast Measurements for Projects 1.14a, 3.1, and 3.10, Operation TEAPOT, ITR-1155," May 1955. (SECRET)

TM 23-200, Capabilities of Atomic Weapons, 1 June 1955. (SECRET)

NAVORD Report 2192, A Copper Indenter Gauge for the Measurement of Peak Pressure, 10 July 1951.

~~RESTRICTED DATA~~

~~RESTRICTED DATA - SECURITY INFORMATION - ENERGY ACT 1054~~

~~RESTRICTED DATA - SECURITY INFORMATION - ENERGY ACT 1054~~

v

APPROVAL OF

Report 1443

THE EFFECTS OF ATOMIC WEAPONS ON
ENGINEER HEAVY EQUIPMENT (U)

25 April 1956

and

DISTRIBUTION

C O P Y

JUN 1 1956

ERD SB
8-12-75-001

SUBJECT: Transmittal for Approval of Report No. 1443, The Effects
of Atomic Weapons on Engineer Heavy Equipment (U)

TO: Chief of Engineers
Department of the Army
Washington 25, D. C.
ENGTN

1. Transmitted herewith is Report No. 1443, "The Effects of
Atomic Weapons on Engineer Heavy Equipment," dated 25 April 1956,
which was prepared by the Technical Staff of the Engineer Research
and Development Laboratories.

2. The report, with its conclusions, is approved.

2 Incls
1. Proposed distr list
(5 cys)
2. Report 1443
(4 cys)

H. F. SYKES, JR.
Colonel, CE
Director

C O P Y

CORPS OF ENGINEERS, U S ARMY
ENGINEER RESEARCH AND DEVELOPMENT LABORATORIES
FORT BELVOIR, VIRGINIA

ADDRESS REPLY TO
COMMANDING OFFICER
ENGINEER RESEARCH AND DEVELOPMENT LABORATORIES
FORT BELVOIR, VIRGINIA



IN REPLY
REFER TO ERD MP

8-12-75-001

22 AUG 1956

SUBJECT: Proposed Distribution List for ERDL Report No. 1443

TO: Chief of Engineers
Department of the Army
Washington 25, D. C.
ENGTN

1. Reference is made to letter, ERD SB 8-12-75-001, Engineer Research and Development Laboratories to Chief of Engineers, 1 June 1956, subject: Transmittal for Approval of Report No. 1443, The Effects of Atomic Weapons on Engineer Heavy Equipment (U).

2. Per conversation between Mr. Stathis, Research and Development Division, and Mr. Davis, Special Projects Branch, these Laboratories, a proposed distribution list is attached as Inclosure 1 to replace distribution list which accompanied above referenced report.

FOR THE DIRECTOR:

1 Incl: (quint)
Proposed distr list

NEIL K. DICKINSON
Chief, Military Engineering Dept.

AUG 24 1956

UNCLASSIFIED

8-12-75-00

ENGNB (ERD MP 22 Aug 56)

~~SECRET~~

lt Ind

SEP 11 1956

SUBJECT: Proposed Distribution List for ERDL Report No. 1443

Office of the Chief of Engineers, Department of the Army, Washington 25, D.C.

TO: Commanding General, Engineer Research and Development Laboratories,
Ft. Belvoir, Virginia

1. ERDL Report No. 1443, "The Effects of Atomic Weapons on Engineer Heavy Equipment(U)" with revised proposed distribution list is approved by the Office Chief of Engineers.

2. Four of the 5 copies of report and distribution list are returned.

FOR THE CHIEF OF ENGINEERS:

2 Incls (quad)

1. (U) Distr list

2. (S) Rpt 1443,
Cys 1,2,3,4
(A-47510)

*w/d for
Tech Plans
Ed...*

R M Whitenton
H. E. BROWN *H Col C. E.*
Colonel, Corps of Engineers
Chief, Engineer Research and
Development Division

"WHEN SEPARATED FROM ATTACHMENTS THIS DOCUMENT BECOMES UNCLASSIFIED"

~~SECRET~~
ATOMIC ENERGY ACT OF 1954

UNCLASSIFIED

This document consists of 1
No. 1 of 7 Copies, Serial

~~SECRET~~

2

11330/T

DISTRIBUTION LIST FOR ERDL REPORT 1443

TITLE: The Effects of Atomic Weapons on Engineer Heavy Equipment (U)

DATE OF REPORT: 25 Apr 56 PROJECT 8-12-75-001 CLASSIFICATION U

Asst Chief of Staff, G-2 Dept of the Army Washington 25, D. C.	2	Chief of Staff Dept of the Army Washington 25, D. C. ATTN: Ch, Res & Dev.	2
Asst Chief of Staff, G-3 Dept of the Army Washington 25, D. C. ATTN: Deputy Ch of Staff, G-3 (RR and SW)	2	Commandant The Artillery School Ft Sill, Oklahoma	2
Chief of Engineers Dept of the Army Washington 25, D. C. ENGEB (Mil Constr)	3	Commanding General Continental Army Command Ft Monroe, Va.	3
Chief of Engineers Dept of the Army Washington 25, D. C. ATTN: Civil Works Div.	3	President Bd No. 1, CONARC Ft Sill, Oklahoma	1
Chief of Engineers Dept of the Army Washington 25, D. C. ATTN: Military Supply Div.	3	President Bd No. 2, CONARC Ft Knox, Kentucky ATTN: Engrng Section	1
Chief of Engineers Dept of the Army Washington 25, D. C. ATTN: Troop Operations Div.	6	President Bd No. 3, CONARC Ft Benning, Ga.	1
Chief of Engineers Dept of the Army Washington 25, D. C. ATTN: Troop Operations Div.	6	President Board No. 4, CONARC Ft Bliss, Texas	1
Army Map Service 6500 Brooks Lane, N.W. Washington 25, D. C. ATTN: Documents Library	2	President Board No. 5, CONARC Ft Bragg, N. C.	1
Asst Commandant The Engineer School Ft Belvoir, Va.	5	President Bd No. 6, CONARC Ft Rucker, Alabama	1
Commandant The Infantry School Ft Benning, Ga.	2	Commanding General First Army Governor's Island, New York 4, N.Y. ATTN: G-3	1

Commanding General Second Army Ft George G. Meade, Md.	2	Office of Chief Chemical Officer Army Chemical Center, Md. ATTN: R and E Div.	1
Commanding General Third Army Ft McPherson, Ga. ATTN: G-3	1	Office, Chief of Ordnance Dept of the Army Washington 25, D. C. ATTN: ORDTX-AR	1
Commanding General Fourth Army Ft Sam Houston, Texas ATTN: G-3	1	Office of the Qm General Dept of the Army Office, Res & Dev Division Project Control Office Rm 2124, Tempo Bldg A Washington 25, D. C.	1
Commanding General Fifth Army 1660 E. Hyde Park Blvd. Chicago 15, Ill. ATTN: G-3	1	Commanding General Qm Res and Dev Center Natick, Mass. ATTN: Tech Library	1
Commanding General Sixth Army Presidio of San Francisco, Calif. ATTN: G-3	1	Office, Chief of Transp. Dept of the Army Washington 25, D. C. ATTN: Exec for Res and Dev	1
Chief, Bureau of Yds & Docks Dept of the Navy Washington 25, D. C. ATTN: P-312	5	Hq, USAF DC/S Development Director of Requirements Washington 25, D. C. ATTN: Communications & Eq Div.	1
Officer in Charge Naval Civil Engrng Res & Eval Lab Construction Battalion Center Port Heuneme, Calif.	1	Hq, USAF DC/S Development Director of Res and Dev Washington 25, D. C. ATTN: Combat Components Div.	1
Chief, Armed Forces Special Weapons Project P.O. Box 2610 Washington 13, D. C.	2	Commander Air Res and Dev Command PO Box 1395 Baltimore, Md. ATTN: Eq Division, RDTDE	1
Commanding General Field Command Armed Forces Spec Weapons Proj PO Box 5100 Albuquerque, N. M.	2	Commander Air Force Special Weapons Center Kirtland, N. M. ATTN: Tech Library	1
Commandant U. S. Marine Corps Washington 25, D. C. ATTN: Code AO3H	5		

Director 1 [REDACTED]
Air University
Maxwell Air Force Base, Alabama
ATTN: A-2 Librarian

Commander 1
Continental Air Command
Mitchell Air Force Base, N. Y.

Commander 1
Wright Air Development Center
Wright-Patterson Air Force Base, Ohio
ATTN: WCLEI, Air Installations Br

Engr Representative 1
U. S. Army Stdzn Group U.K.
Box 65, U. S. Navy 100
Fleet Post Office
New York, N. Y.

Commandant 1
Armed Forces Staff College
c/o Naval Operating Base
Norfolk, Va.
ATTN: Library

Sr U. S. Representative 1
DWD Army Hq
Ottawa, Canada

Officer in Charge 1
Army War College
Carlisle Barracks
Carlisle, Pa.
ATTN: Library

The Archives 1
The Command and General Staff College
Ft Leavenworth, Kansas
ATTN: Sr Engineer Instructor

Signal Corps Engineer Lab 1
Ft Monmouth, N. J.
ATTN: Engr Liaison Officer

Commander 1
Wright Air Dev Center
Wright-Patterson Air Force Base, Ohio
ATTN: WCLE, Equipment Lab

[REDACTED]

[REDACTED]

ED